



HR Wallingford

Mathematical Model of Groynes on Shingle Beaches

A H Brampton BSc PhD

D G Goldberg BA

Report SR 276

November 1991

This report describes an investigation carried out by HR Wallingford under contract CSA 1437, "Mathematical Model of Groynes on Shingle Beaches", funded by the Ministry of Agriculture, Fisheries and Food. The departmental nominated officer for this contract was Mr A J Allison. The company's nominated project officer was Dr S W Huntington.

This report is published on behalf of the Ministry of Agriculture, Fisheries and Food, but the opinions expressed are not necessarily those of the Ministry.

© Crown Copyright 1991

Published by permission of the Controller of Her Majesty's Stationery Office

Mathematical model of groynes on shingle beaches

A H Brampton BSc PhD
D G Goldberg BA

Report SR 276

November 1991

ABSTRACT

This report describes the development of a mathematical model of a shingle beach with groynes. The development of the beach plan shape is calculated given information on its initial position and information on wave conditions just offshore. Different groyne profiles and spacings can be specified, so that alternative groyne systems can be investigated. The model includes a method for dealing with varying water levels as the result of tidal rise and fall.

CONTENTS

	Page
1. INTRODUCTION	1
2. SCOPE OF THE MODEL	3
2.1 Model resolution and input conditions	3
2.2 Sediment transport mechanisms	6
2.3 Vertical distribution of sediment transport	8
2.4 Wave transformation modelling	10
3. DESCRIPTION OF THE MODEL	10
3.1 Plan shape changes	11
3.2 Beach profile changes	14
3.3 Calculation of the distribution of cross-shore transport	15
3.4 Representation of groynes	19
4. INITIAL RESULTS AND FUTURE CALIBRATION	21
5. REFERENCES	25

FIGURES

1	Continuity equation
2	Model of shingle beach profile
3	Distribution of longshore transport
4	Tidal levels at Hythe - probabilistic description
5	Simplified beach with groyne
6a	Beach development for 3 groyne system (0-1 year)
6b	Beach development for 3 groyne system (1-10 years)

1. INTRODUCTION

Around much of the coastline of England and Wales the natural defences against erosion and flooding are shingle beaches. In the south and east of England in particular, from Lyme Bay to The Wash, shingle beaches defend often heavily populated, low-lying areas. The problems of erosion and flooding here are all the greater because the underlying geology is of sedimentary rock and both downward settling of the land mass and eustatic changes in sea levels contribute to a rather rapid submergence of the nearshore seabed, reaching 300mm/century in some areas.

The shingle itself is typically of chert or flint, with median particle diameter between 5mm and 50mm, and is often a relict of past geological ages. Most of the shingle on the beaches of south-eastern England, for example, was originally deposited by the action of peri-glacial rivers before the end of the last Ice Age. Although shingle is added to beaches by erosion of cliffs or the nearshore seabed in some areas, the supplies of fresh material are generally small and diminishing as coastal cliffs are defended.

A wide, healthy shingle beach is a considerable asset to a coastal community. Despite the coarseness of the material, such beaches have been popular with tourists since sea-bathing gained royal patronage in the Regency period. Many of the earliest coastal engineering works on shingle beaches were designed from a recreational viewpoint. More pressing nowadays is the need to prevent inundation of the land behind the beaches, and to prevent erosion or landward migration of the beaches themselves.

The traditional method of management of shingle beaches in the UK has been to install closely-spaced

vertically-faced timber groynes, usually of tropical hardwood, to prevent movement of the coarse beach material alongshore. Often, in addition, vertically faced walls of concrete or masonry were built at the crest of the natural beach to prevent occasional overtopping and to support a promenade or roadway along the coast. Erosion problems "downdrift" of such works were often experienced, due to the interruption of the natural transport of beach material, and such problems were often tackled using very similar groynes and seawalls.

In more recent times, alternative or complementary methods of managing shingle beaches have been used. Mechanical re-cycling or bypassing of shingle has been carried out for decades. As an example, the shingle which accretes against the western side of the training wall at Rye Harbour in Sussex has been placed into trucks and returned to the beach further west (Pett) for many years. Recent innovations have allowed major shingle beach nourishment schemes to be carried out economically, such as at Seaford in 1987 when material was pumped directly ashore through a floating pipeline by the dredger which gathered the material from an offshore area.

In some situations the use of active beach management techniques such as re-cycling or periodic re-nourishment will replace the use of groynes. In many more cases, however, groynes will still have a useful role to play in stabilising shingle beaches. In order to decide on an appropriate management strategy, a numerical model which can simulate beach development including the effects of alternative groyne fields as well as nourishment and recycling is a valuable design aid. It is this reasoning which led to the present research study.

2. SCOPE OF THE MODEL

The modelling of beach changes in the vicinity of coastal structures is beset with difficulties. On one hand, if a model is to be of practical use to a coastal engineer it must be capable of producing accurate predictions of beach changes over a period of years whilst being economical and simple to run.

On the other hand, the various interactions between waves, tides, coastal structures and sediment transport are often extremely complex. Even a simplified representation of some of these processes may require very large computational effort coupled with detailed information or measurements from each site to provide a satisfactory validation or calibration.

Because of these contradictory requirements, it is necessary to make decisions on the scope of the model at an early stage. Some physical processes can be excluded because they are unimportant, whilst others may have to be simplified or ignored because they cannot be modelled. This chapter focuses on the factors which are important in the development of a groyned shingle beach, and on the selection of the processes which have been incorporated in the model.

The principal objective of the model is to predict beach changes, over a period of years, under different management strategies including different groyne layouts.

2.1 Model resolution and input conditions

An important consideration in setting up a numerical model is the required resolution, and how that

resolution will influence the required input conditions. In many areas of the UK, groynes on shingle beaches are built at spacings of 50m or less. As a result, it is necessary to set a fine alongshore spacing (5-10m) in order to represent adequately the beach plan shape within each bay.

Another consequence of such narrow compartments is that the orientation of the beach contours can change very rapidly during a storm. To ensure that the calculated breaking wave conditions and the beach morphology do not "clash" and cause numerical instabilities, it becomes necessary to use small timesteps in the model (about 1-3 hours or less in violent storms). When the requirement is to study the evolution of a many-groyned beach over several years, the number of timesteps and positions along the shore both become large. This influences the complexity of the modelling that can be carried out whilst still retaining an economical design method (see sections 2.2 - 2.4 below).

It is also important to bear in mind from the outset that any numerical model will depend on the accuracy of its input data in producing accurate results. Careful consideration has to be given therefore, to what information the coastal manager can be expected to provide, especially when he or she is interested in predicting of future beach development as well as explaining past beach changes.

Specification of an initial beach plan shape, the position of seawalls and the positions and shapes of existing or proposed groynes is usually straightforward. Similarly, information on beach material and beach profiles can usually be obtained quickly or, in the case of a proposed new beach,

estimated reasonably accurately. More difficult to specify are the time varying input conditions which produce changes in the beach.

The main time-varying input information required for the BEACHPLAN model is wave data. Four different methods of prescribing wave conditions are possible, as follows:

1. A single 'morphological' average wave condition assumed to persist throughout the whole period for which the model is run.
2. Several 'typical' wave conditions, arranged in a pre-specified sequence which repeats over the period of the model run.
3. A sequence of wave conditions chosen from a directional wave climate specified by the probability of any combination of wave height, period and direction occurring. The sequence has to be chosen by some random-choice algorithm.
4. A sequence of wave conditions (wave heights, periods and directions) which has been recorded or calculated retrospectively (ie hindcast) from recorded wind data.

In many situations it is found that initial runs of the model are best carried out with a single wave condition (option 1) followed by sophisticated wave input conditions at a late stage. In option 2, the need to specify the sequence of wave conditions can introduce some subjectivity into the modelling; this is avoided in option 3 but considerable difficulty is often encountered in ensuring that a realistic sequence of conditions is generated. Option 4 is often the best, provided sufficient data is available to ensure that the sequence available is

representative of the long term climate (eg creates the average nett longshore sediment transport). The choice of an appropriate method of specifying wave inputs therefore has to be matched to the availability of data for any particular model application.

In order to be of maximum use to coastal managers, the model also needs to be able to represent artificial addition or removal of material at different points and at different times. This then allows evaluation of techniques such as re-nourishment, by-passing and re-cycling, alongside purely structural methods of beach management. Since such operations will be dictated by the time of year, for example to avoid disruption to tourists, as well as the state of the beach, the specification of how and when to add or remove beach material also has to be regarded as a time dependent input.

2.2 Sediment transport mechanisms

Around the world, the major cause of long-term beach changes is the variation in longshore sediment transport from point to point along the coast. Most of the spectacular examples of coastal erosion are the results of the deliberate or accidental interruption of the natural sediment transport along the beach (see, for example, Ref 1). Usually this longshore sediment transport is produced by waves arriving at an angle to the beach, although tidal currents can be an additional factor. For shingle beaches, which often only occupy the upper portion of the foreshore (ie above the low water mark), tidal currents are unlikely to be significant in comparison to those created by waves and are therefore ignored in the present investigation.

Although beach material also moves perpendicular to the contours under the influence of waves, it is rather unusual to find that onshore-offshore movement produces a long-term nett erosion or accretion of a beach. Seasonal changes, or changes brought about by particular events such as severe storms, can result in substantial changes in the beach profile, however, and to be realistic account must be taken of this behaviour. It is often observed that shingle escapes around the ends of groynes during winter storms, when large waves have combed down the beach to a flatter profile. In summer, however, when the beach is steeper the groynes are generally much more efficient.

In the model developed in this study, therefore, it is assumed that there are no losses or gains offshore (except for the artificial, user-specified renourishment or dredging rates referred to in 2.1 above), but that it is necessary to take account of changes in the beach profiles resulting from the changing wave conditions. Because of the long period for which the model has to be run, and the detailed resolution required (see section 2.1 above), it was not considered feasible to produce a fully 3-dimensional beach model. Instead a mathematical model of the development of the plan shape of a beach was modified to also include predictions of the beach profile under wave action. These profile predictions are carried out using empirical formulae developed under a research contract also carried out by HR Wallingford for the Ministry of Agriculture, Fisheries and Food (Ref 2) which involved scale physical model testing of shingle beaches, calibrated against field data.

2.3 Vertical distribution of sediment transport

A complicating factor in modelling shingle beaches is that in most situations the shingle only covers a part of the active beach profile. At a few sites such as Orfordness and Dungeness, the shingle does extend well below the low water mark. At other sites the shingle continues throughout the inter-tidal zone, but then terminates abruptly on a hard rock 'bench' below low water. Most commonly, however, the shingle only occupies the upper part of the inter-tidal zone, giving way to sand by the time the low water mark is reached. Groynes built in such mixed sand and shingle beaches often only extend far enough to retain the shingle and this type of structure has to be represented in the mathematical model.

For a fixed water level, therefore, and given incident wave conditions, the vertical distribution of the longshore sediment transport needs to be established. That is to say the proportion of the total transport which travels along the coast between any two contours on the beach face has to be determined. This is a rather tricky problem to tackle, not least because of the difficulty in obtaining field measurements to validate the distribution adopted. It was also considered important to adopt a formulation which was simple to use and could be incorporated as an adaptation to existing, proven models of beach evolution rather than requiring a completely new model.

After examining a number of articles and reports covering both theoretical approaches and site measurements (Refs 3-7), it was decided to rely again

on laboratory studies carried out at HR Wallingford under a related research contract. An empirically derived function expressing the transport distribution as a function of distance from the swash limit to the breaker line was therefore adopted. The position of both these lines relative to the still water level depends on the incident wave conditions. A further complication which has to be taken into account arises as the result of the rise and fall of the tide. Some shingle beaches along the central south coast of England experience only a very modest tidal range, as small as 0.5m in places. Elsewhere, however, the range can exceed 6.0m with the shingle only being in the water for a small percentage of the tidal cycle. Whilst the effects of tidal currents can be ignored, the tidal range cannot.

As previously, a decision had to be made at an early stage on the method of incorporating such effects. It was not considered practical to provide time-series input to the model which included both tidal levels and wave conditions of regular intervals of a few hours, although this would certainly allow the consequences of any link between surges and large waves to be studied. Instead, the model was developed to use statistical information on tidal levels, derived from long term tide level records. This information is provided in the form of a histogram which gives the probability of the tidal level at any moment being in specified ranges (eg between Mean Sea Level and MSL+1.0m). This information is then combined with the formula for the distribution of longshore transport down the beach face for a fixed water level to provide a modified distribution function for any incident wave condition. The model can then be run with this 'averaged' distribution without needing to know anything about the changing tidal level.

2.4 Wave transformation modelling

As a beach changes, for example in response to the construction of a groyne field, so the waves approaching that beach will also change. An important part of a model of beach evolution is this 'feedback' mechanism, where changes in morphology alter the waves which in turn alter the morphology.

In the model the shoaling and refraction of waves, from a point some distance offshore to the breaker line, are calculated using the assumption of locally parallel contours. Such calculations have to be carried out at regular time intervals especially if beach changes are taking place rapidly, for example within a groyne bay.

Some coastal structures such as jetties or harbour arms can not only interrupt the longshore sediment transport but also substantially modify wave conditions for some distance along the coast. As a general rule, groynes on shingle beaches are relatively short, often not reaching the low water mark, and offer little protection to wave action on their leeward face. To avoid expensive computations of a minor effect, it was decided not to calculate wave diffraction around the groyne tip, nor reflections from the up-wave groyne face.

3. DESCRIPTION OF THE MODEL

The mathematical model of a groyned shingle beach has been built up using four main elements which are now briefly described.

3.1 Plan shape changes

The primary and most substantial part of the new model carries out predictions of beach plan shape changes due to variations in longshore sediment transport. It is based on an existing well-established model developed by HR Wallingford over the last 20 years or so (Ref 8). The beach plan shape is specified by the position of a single contour, usually chosen as a particular high tide level or Mean Sea Level; the shape of this contour is defined by a set of co-ordinates in the horizontal plane (x,y) and the model calculates the movement of this contour at regular time intervals.

A rectangular co-ordinate system is established with the model baseline (x-axis) set behind and parallel to the general trend of the coastline. The heart of the model is the equation for the continuity of beach material, namely:

$$\frac{\partial Q}{\partial x} + \frac{\partial A}{\partial t} + q = 0 \quad (1)$$

where Q is the volumetric rate of longshore sediment transport, A is the cross-sectional area of the beach, t is time, and q is the volumetric rate (per unit length of beach) of addition or removal of beach material.

It is assumed that changes in the cross-sectional area of the beach at any point along the coast can be linearly related to the changes in the position of the chosen contour, ie that:

$$\frac{\partial A}{\partial t} = D \frac{\partial y}{\partial t} \quad (2)$$

where D is a depth which remains constant in time, known as the "closure depth". This is a standard

assumption used in all beach plan shape models of the "one-contour" type and is consistent with the concept that the beach profile remains constant in shape in the long-term. A simplified visual interpretation of the continuity equation (ignoring any artificial nourishment, ie with $q = 0$) is provided in Figure 1. In this figure the beach profile is shown as an inclined plane moving parallel to itself as the beach erodes or accretes. In practice, of course, the mean beach profile has a more complex shape, and the determination of the closure depth, D , is best carried out by directly relating changes in area and the position of the beach contours using data from the site being studied. Combining equations 1 and 2 gives:

$$\frac{\partial Q}{\partial x} + D \frac{\partial y}{\partial t} + q = 0 \quad (3)$$

Starting from an initial beach contour position, and given an initial incident wave condition, the model evaluates the longshore sediment transport rate, Q , at points δx apart along the baseline. Equation 3 is then used to produce predictions of the changes in beach position (δy) over the timestep (δt), taking into account any nourishment or mining ($q\delta t$) during that time. The shoreline position is then revised, an incident wave condition specified for the next timestep, and the calculations repeated. For each ordinate, x_i , along the baseline the successive positions of the representative beach contour, $y_i(0)$, $y_i(\delta t)$, $y_i(2\delta t)$, are calculated, analysed and output.

An important part of the model is the accurate calculation of the volumetric rate of longshore sediment transport produced by the breaking waves. For waves breaking on a beach with nearly straight contours, Q can be well approximated by:

$$Q = K_1 (\gamma_s)^{-1} E_b (nC)_b \left[\sin 2\alpha_b - K_2 \frac{\partial H_b}{\partial x} \cot\beta \cos\alpha_b \right] \quad (4)$$

where

K_1, K_2 are non-dimensional coefficients

E is the wave energy density ($= 0.125\rho gH^2$)

H is the wave height

g is the acceleration due to gravity

ρ is the water density

γ is the submerged weight of beach material in place

nC is the group velocity of the waves

α is the angle between their crests and the local depth contours

$\tan\beta$ is the mean slope of the beach face and where

b used as a subscript denotes breaking wave conditions.

The first term in Equation 4 is the well known CERC (Scripps) formula and describes the alongshore sediment transport due to obliquely breaking waves. The second term takes into account the transport created by any alongshore variation in breaking wave height, which becomes important for beaches in the lee of headlands or breakwaters where diffraction effects are significant. In the present model this term is generally ignored ($K_2=0$).

3.2 Beach profile changes

As pointed out in Chapter 2, there is a need when modelling shingle beaches to incorporate predictions of profile changes. A severe storm can produce a landward movement of the high water line which is larger than the result of several years of gradual erosion due to interruption of the longshore sediment transport. If such a retreat then results in the exposure of the seawall to direct wave action, this is of fundamental interest to a coastal manager, not least because shingle beaches often scour rapidly when this situation occurs. A useful feature of the model therefore, is its ability to identify where, and when, a seawall is exposed by the erosion of a beach.

Although modelling the response of the beach profile is useful, it is impractical to use a fully three-dimensional representation of the beach morphology and its changes. Instead an empirically derived representation of the beach profile is used, based on an idea originally put forward in studies of rock revetments (Ref 9) but extended to shingle beaches at Wallingford (Ref 2). Briefly, three different portions of the beach profile are defined, namely:

- beach crest to still water line (SWL),
- SWL to transition point (see below),
- transition point to lower profile limit,

and a hyperbolic function defined in each portion to define the complete beach profile. The 'transition point' is defined as the location where turbulence under the breaking waves becomes fully developed, and on shingle beaches is usually identifiable by a change

in the beach slope. A more detailed description of this representation of the profile is given in Figure 2, whilst the experimental procedures and derivation of the various parameters is given in Reference 2. The method has been validated against field data, and is now in use as a design tool for engineers wishing to examine the response of an existing or proposed beach cross-section to severe storm conditions.

Although this empirical profile prediction method is presently the best available, there are situations in which it may not give reliable results - for example when the shingle beach only occupies a limited portion of the beach profile. The modular construction of the present model of groyned shingle beaches will enable future and improved formulations to be incorporated when (and if) they become available.

3.3 Calculation of the vertical distribution of cross-shore transport

As mentioned in section 2.3 above, groynes on shingle beaches rarely extend to the low-water line, let alone down to the bottom of the active beach profile. They cannot therefore be assumed to be totally efficient at arresting the longshore sediment transport. This leads to the necessity of calculating how much of that transport they do intercept; that is to say their efficiency has to be evaluated. To achieve this, it is necessary to have a reasonably accurate idea of the distribution of the longshore sediment transport down the beach face.

The first situation to consider is when the still water level is fixed (ie no tidal rise or fall). Sediment transport along a coast takes place above this level, to the swash limit, and from there seawards to beyond the breaker line. Obtaining reliable data on the distribution of transport within this very dynamic zone is extremely difficult. There are three possible types of methods which have been used in the past, namely theoretical modelling, laboratory modelling and field measurements.

Most of the field measurements have been carried out on sandy beaches where transport in the water (suspended load) has to be considered as well as that along the sea floor (bed load) - see for example the experiments at Duck, North Carolina (Refs 3 & 4). Some field experiments have been carried out on shingle beaches, notably work by Dr Andrew Chadwick (Brighton Polytechnic) who made measurements at Shoreham Beach. However, these experiments relied on sediment traps which are often unreliable, and the validity of the results is questioned by even the author (Ref 5).

Laboratory experiments in a wave basin have the advantage of being carried out in controlled conditions, but end effects are a worry, and the efficiency of sediment traps is still suspect.

Finally, there have been considerable advances in the numerical modelling of surf-zone dynamics in recent years but such models are still incomplete, complicated and lacking in validation on shingle beaches. Faced with a variety of methods none of which were free of problems, it was decided to use a simple formulation derived from wave basin experiments. These were carried out at Wallingford

and provided a reasonable, simple function illustrated in Figure 3. The distance offshore, x , is scaled relative to x_b , the distance between the wave run-up limit and the breaker line, and it was found that the distribution has a peak value at about $x/x_b = 0.7$ (Ref 7).

The run-up limit, R_s , is defined by;

$$R_s = \begin{cases} I_r \times H_s & I_r \leq 2.5 \\ H_s \times (2.5 - (I_r - 2.5)/3) & 4 > I_r > 2.5 \\ 2 \times H_s & I_r \geq 4 \end{cases} \quad (5)$$

where I_r is the Iribarren number ($=\tan\beta/(H_s/L_m)^{1/2}$)

$\tan\beta$ is the beach slope

L_m is the mean wave length and

H_s is the significant wave height

This formula for normally incident waves is given by Losada and Gimenez-Curto (Ref 10) and was validated for shingle beaches in laboratory flume tests at Wallingford (Ref 2). To account for angled wave attack a modification to the formulation is required, and the run-up limit given in equation 5 is multiplied by the following factor;

$$\cos\theta (2-\cos^2\theta)^{1/3} \quad (6)$$

which was proposed in Reference 11.

The breaker point is defined by the simple equation

$$H_b = 0.78 d_b \quad (6)$$

where H_b is the (root-mean-square) wave height at breaking and d_b is the local water depth there.

This equation is solved by an iterative numerical solution to the equations used to predict the nearshore transformation of waves by refraction and shoaling.

Having specified the distribution down the beach face of the longshore transport for a fixed water level, it is now necessary to take into account the effects of varying tidal levels. Since it is often difficult to obtain time-series data for tidal levels at particular sites, and would complicate modelling even if the data could be obtained, a probabilistic approach has been adopted. Figure 3 shows a probabilistic distribution of water levels at Hythe, in Kent, derived by adjusting data from the nearby standard port at Dover. For each tidal level increment (in this case 0.5m steps) the central value is used to calculate a cross-shore distribution of the longshore sediment transport. By forming a weighted average of all these distributions, using the relative probabilities of the tidal level being within a given range, an averaged distribution can be obtained.

It is worth noting here that such overall averaging has led to some interesting and surprising results at several sites around the UK coast. The commonly occurring small waves from one direction may well

balance the transport caused by larger but much less frequent waves from another. However, the smaller waves will only move sediment close to the water level whilst the larger waves produce transport lower down the beach face. As a result it was calculated at Aldeburgh, for example, that the nett longshore sediment transport is in different directions at different levels down the beach face.

3.4 Representation of groynes

The last major element of the mathematical model deals with groynes, their specification and efficiency. As a first step, an input data file is set up containing information on the position and cross-section of each groyne. Since groynes are not always parallel to one another, the cross-section of each projected into a plane perpendicular to the baseline has to be specified. If groynes are inclined at a significant angle to the beach perpendicular (more specifically to the model baseline perpendicular) then some errors will inevitably result. It is also assumed that no material travels through the groyne or over its crest (unless it is buried below beach level).

It is not practical to model the very complex flow patterns in and around the groynes so a simplified approach to groyne efficiency is adopted. First it is necessary to determine the beach profile on the 'updrift' side of the groyne. (On rare occasions the drift may be in different directions on each side of the groyne but in this case it is reasonable to assume the groyne is totally efficient). The profile against the groyne face is estimated by extrapolation from the beach contours on that side of the groyne. Generally, groyne profiles slope more steeply than the beach, so

that the groyne crest and beach profile only meet at a single place (see Fig 5). By comparing the fixed groyne profile and the varying beach profile, it is possible to define the level (d on Fig 5) along the contour where the groyne emerges from the beach. Knowing this level and the distribution of longshore sediment transport, calculated as described in section 3.3 above, it is straightforward to calculate the percentage of the transport taking place above this contour on the beach updrift from the groyne. It is then assumed that the groyne traps just that percentage of the transport, allowing the remainder to pass the end of the groyne.

If the groyne profile does not shelve more steeply than the beach profile, then more complex calculations would be required but the same general approach can still be used.

4. INITIAL RESULTS AND FUTURE CALIBRATION

Preliminary results from the model have been encouraging, with the predicted beach plan shapes exhibiting features often seen on natural shingle coastlines. Figure 6 shows a forecast of beach development within a simple groyne field along a straight coastline. The layout is hypothetical but the parameters used, ie the beach and groyne dimensions and the incident wave conditions, are typical for the southern or eastern coast of England. Figure 6a shows the beach changes between and close to the three groynes, over 12 months, under continuous wave action of significant height 1m and direction 20° from normal to the original shoreline. Initially, the beach orientation in the groyne bays simply alters to face the incoming waves; since no material is able to pass around the end of the groynes within the first month the beach plan shape in each bay is identical. Notice that in the absence of any shelter from the updrift groyne, the beach line is straight in each bay. The advance of the beach on the updrift side of the groynes is roughly equal to the erosion downdrift.

As time proceeds material starts to bypass the groynes, the updrift groyne bay filling more rapidly. In each bay the volume of material entering from the updrift side is greater than the volume leaving over the downdrift groyne - because the beach is further seaward just updrift of each bay than within the bay itself. Apart from slowly filling the bay, this also produces a gradual change in the beach orientation.

Notice also that the rate of downdrift erosion beyond the groyne system is greater than the rate of accretion updrift. This is because some of the drift is being retained by the groynes. The maximum erosion

immediately downdrift of the groyne occurs in this example between 8 and 12 months after the start of the simulation. Thereafter sufficient material is bypassing the groyne to prevent further localised erosion, although erosion continues further downdrift. Figure 6b demonstrates the further development of the shoreline, and illustrates beach changes further afield. Note that changes within the groyne bays eventually become very slow, and that the point of maximum erosion moves slowly downdrift with time. Since the groyne is a permanent block to the drift, accretion continues indefinitely on their updrift side, and erosion correspondingly continues on the downdrift flank.

The ability of the model to predict beach changes within groyne bays, and along the surrounding coast, over 10 years is an important step. No serious problems of instability were encountered provided a suitable timestep was chosen. Further improvements can be anticipated, particularly by incorporating wave sheltering effects produced by the updrift groyne. Comparison of alternative groyne layouts can already be carried out without this sophistication .

A more important advance would be to calibrate the model against actual beach changes in and around a groyne field. Despite widespread searches, no suitable data could be located for this purpose. It certainly would be possible, although expensive, to digitise information from aerial surveys such as that carried out by NRA (Southern) along the coasts of south-east England. However, these surveys are only carried out once a year and this is unsuitable for calibration purposes. Single 'snapshots' of beach contours would be of limited value, especially if there was wave information available at or just before the survey data.

It is therefore likely that a programme of beach surveys will have to be carried out specifically, if an adequate calibration of the model against prototype beach changes is to be achieved. Such surveying would have to be planned in advance at a suitable site, perhaps as part of a post-project appraisal for a coast protection or sea defence scheme. Mathematical modelling and survey data analysis could be carried out as a complementary exercise to the beach measurements, which would be most economically performed by local personnel, eg from a local authority or students from centres of higher education.

At least initially, it would not be necessary to carry out any wave recording since adequate information on waves could be deduced by numerical hindcasting techniques. An appropriate first exercise would be to survey a small groyne field (10 groynes or less), four times at monthly intervals (during the summer months) and examine the results obtained alongside a mathematical simulation. This would suggest both improvements to the model, and further surveying work required.

An alternative way to proceed is to calibrate the model described in this report against beach changes recorded in controlled conditions in the laboratory. This was the original method used for calibrating the one-line beach planshape model many years ago (Ref 12). It would then be possible to refine the present model in the coming years using laboratory data on an opportunistic basis, prior to any further work on improving the assumptions made in its formulation.

This approach, however, is likely to be slow. Suitable opportunities for such work are few, and difficult to predict sufficiently far in advance to allocate appropriate resources.

A rather surer way to proceed would be to carry out dedicated modelling but this would be much more expensive. Both types of laboratory testing are, of course, subject to possible criticism because of scale effects. For this reason prototype measurements, as discussed above seem the best way to proceed.

REFERENCES

1. Galvin, CJ. Importance of Longshore Transport, Shore and Beach, January 1990
2. "Predicting short term profile response for shingle beaches", HR Wallingford, Report SR219, February 1990
3. 'Duck 85 surf zone sand transport equipment', Technical Report CERC-89-5, US Army Engineer Waterways Experiment Station, Coastal Engineering Research Center, Vicksburg, MS, 1989
4. Rosat, JD, Gingerich KJ and Kraus NC. SUPERDUCK surf zone sand transport experiment, Technical Report CERC-90-10, US Army Engineer Waterways Experiment Station, Coastal Engineering Research Center, Vicksburg, MS, 1990
5. Chadwick, AJ. Sediment dynamics on open shingle beaches. Report on Shoreham Beach field measurement programme, Brighton Polytechnic, 1987
6. Southgate, HN. A nearshore profile model of wave and tidal current interaction, Coastal Engineering, 13, 1989
7. Lowe, JP. Angled wave attack on beaches, HR Wallingford, (Report in preparation), 1991
8. Brampton, AH and Motyka JM. 'Modelling the plan shape of shingle beaches', Lecture Notes on Coastal and Estuarine Studies, 12, Offshore

and Coastal Modelling - Proceedings of the 7th POLYMODEL conference, Sunderland Polytechnic, 1984

9. Van der Meer, JW. Rock slopes and gravel beaches under wave attack, Delft Hydraulics Communication No. 396, 1988
10. Losada, MA and Gimenez-Curto, LA. Flow characteristics on rough permeable slopes under wave action, Coastal Engineering, 4, 1981
11. Tantanheim, E, Kohlase, S and Partenscky, HW. Wave run up at sea dikes under oblique wave approach, Proc. 18th International Coastal Engineering Conference, ASCE, Cape Town, 1982
12. Price, WA, Tomlinson, KW, and Willis, DH. Predicting Changes in the Plan Shape of Beaches, Proc 13th Coastal Engineering Coastal Engineering Conference, ASCE, 1973, pp 1321-1329.

Figures

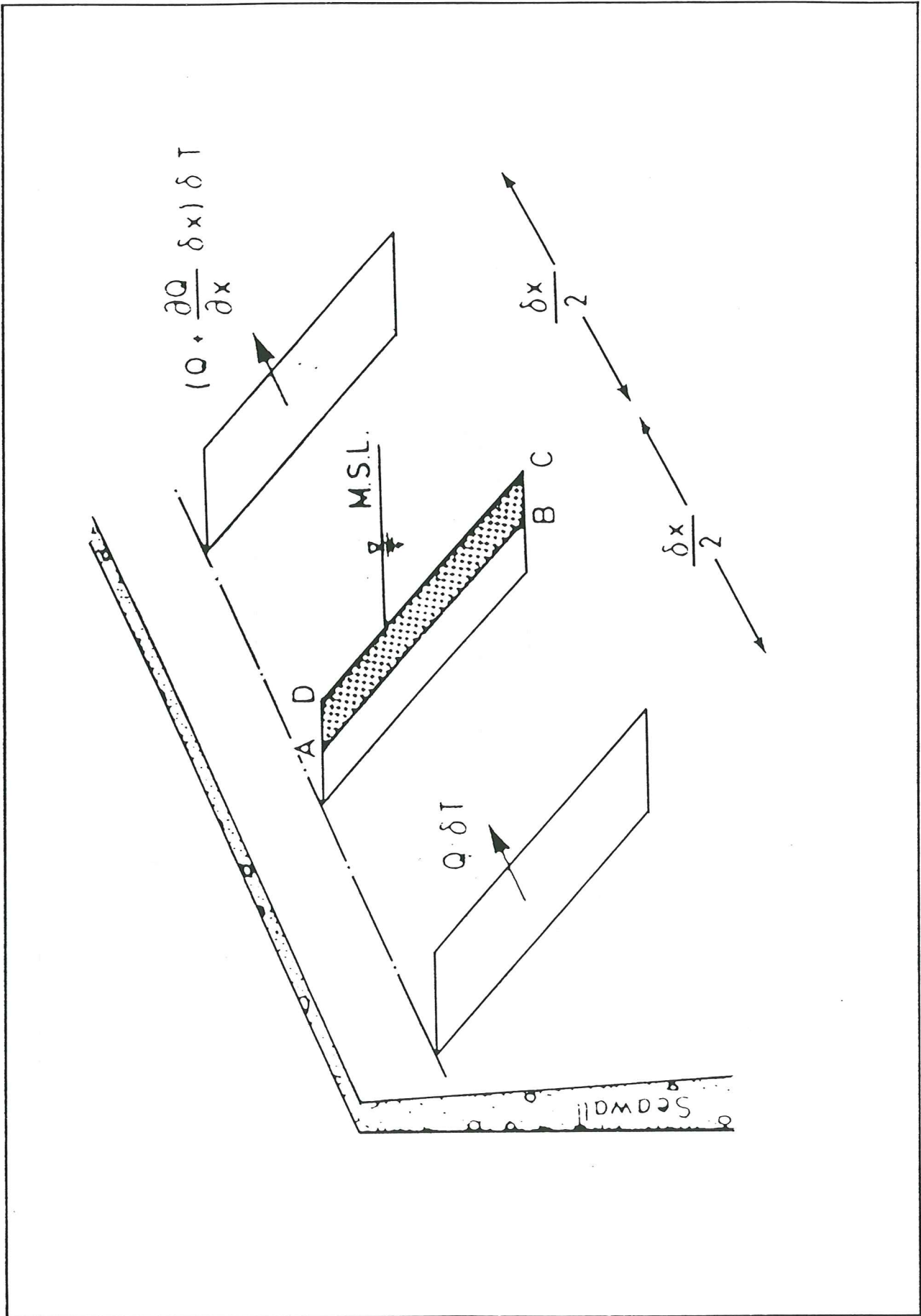

Fig 1 Continuity equation.

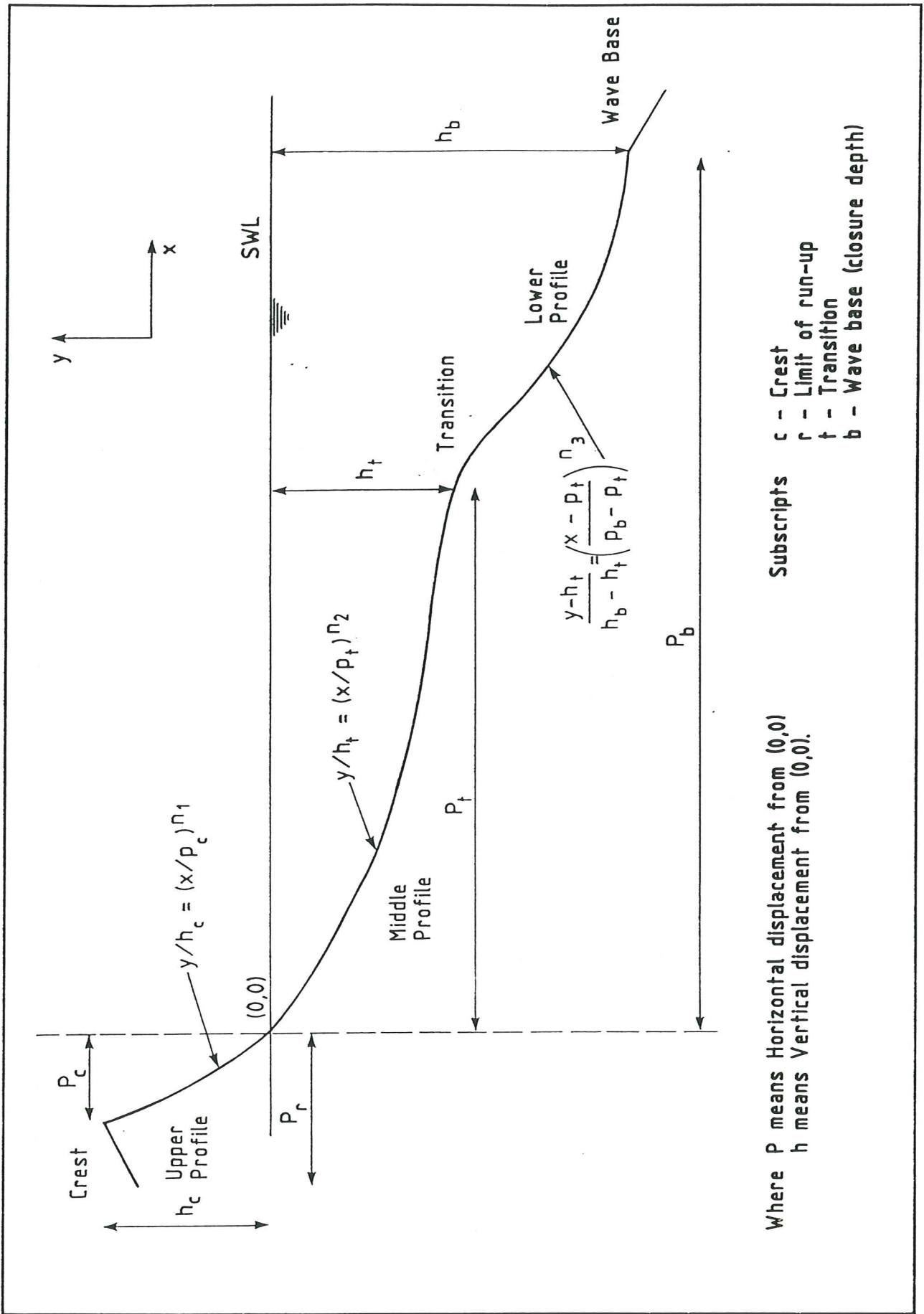

Fig 2 Model of shingle beach profile.

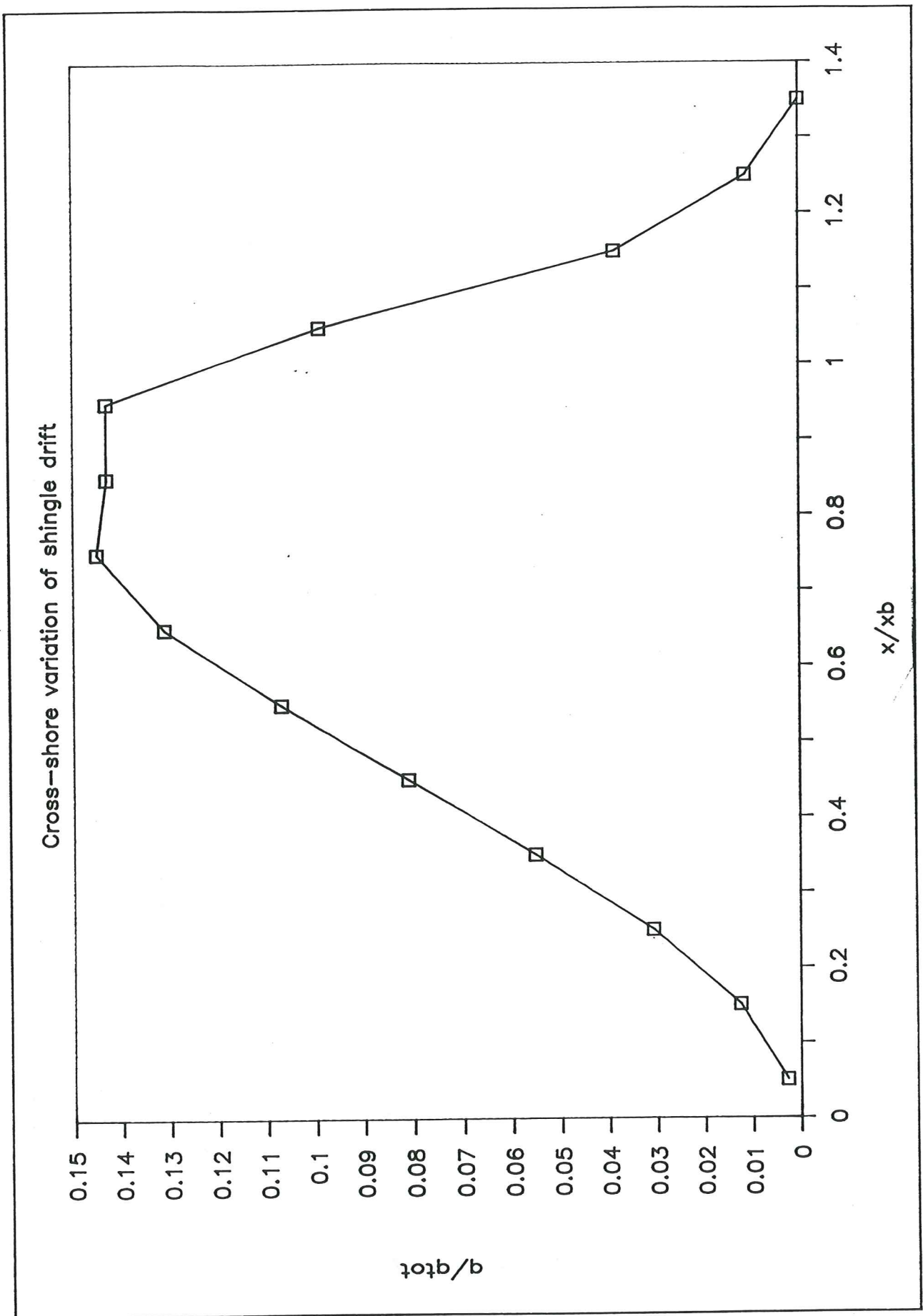

Fig 3 Distribution of longshore transport.

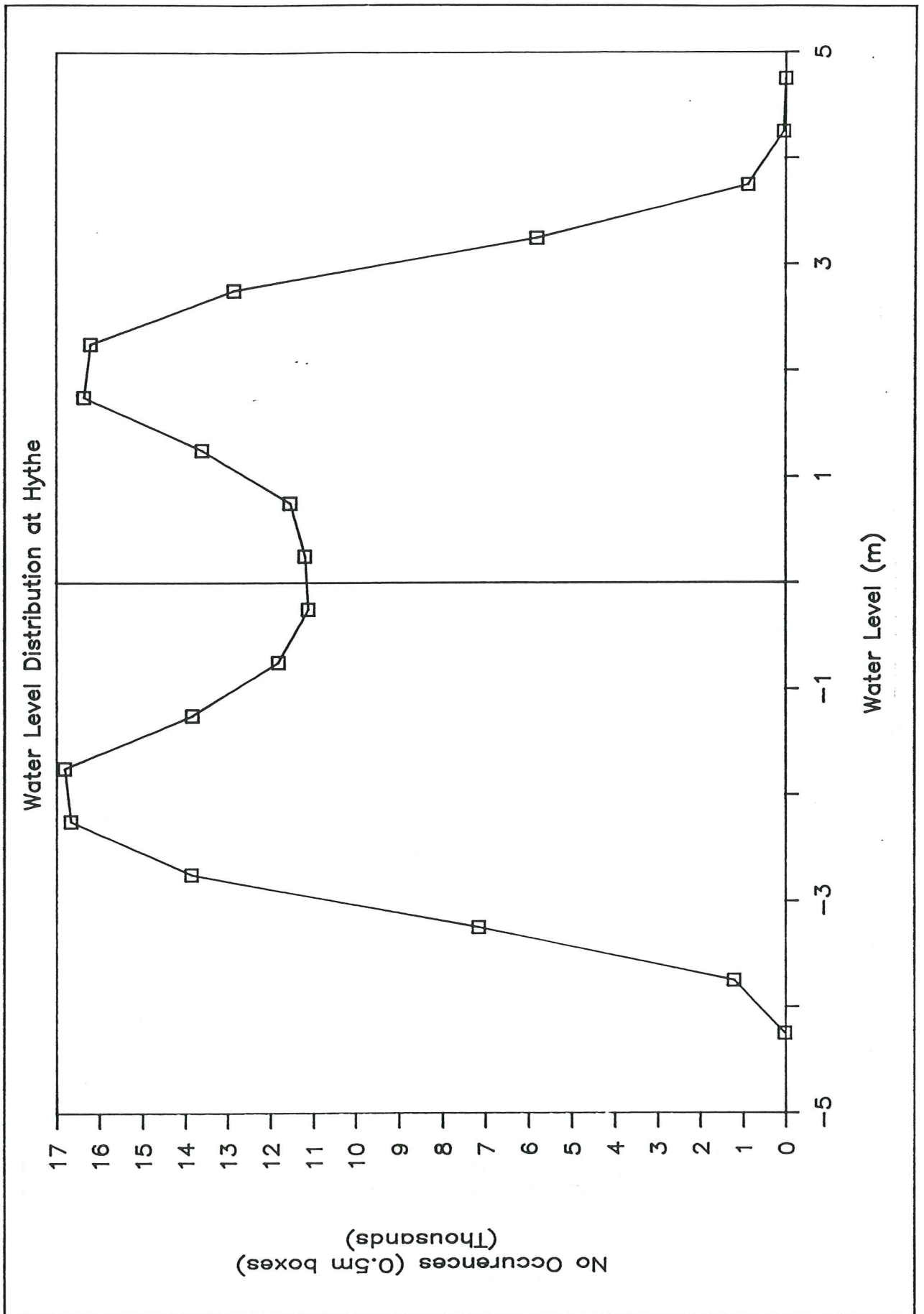

Fig 4 Tidal levels at Hythe - probabilistic description.

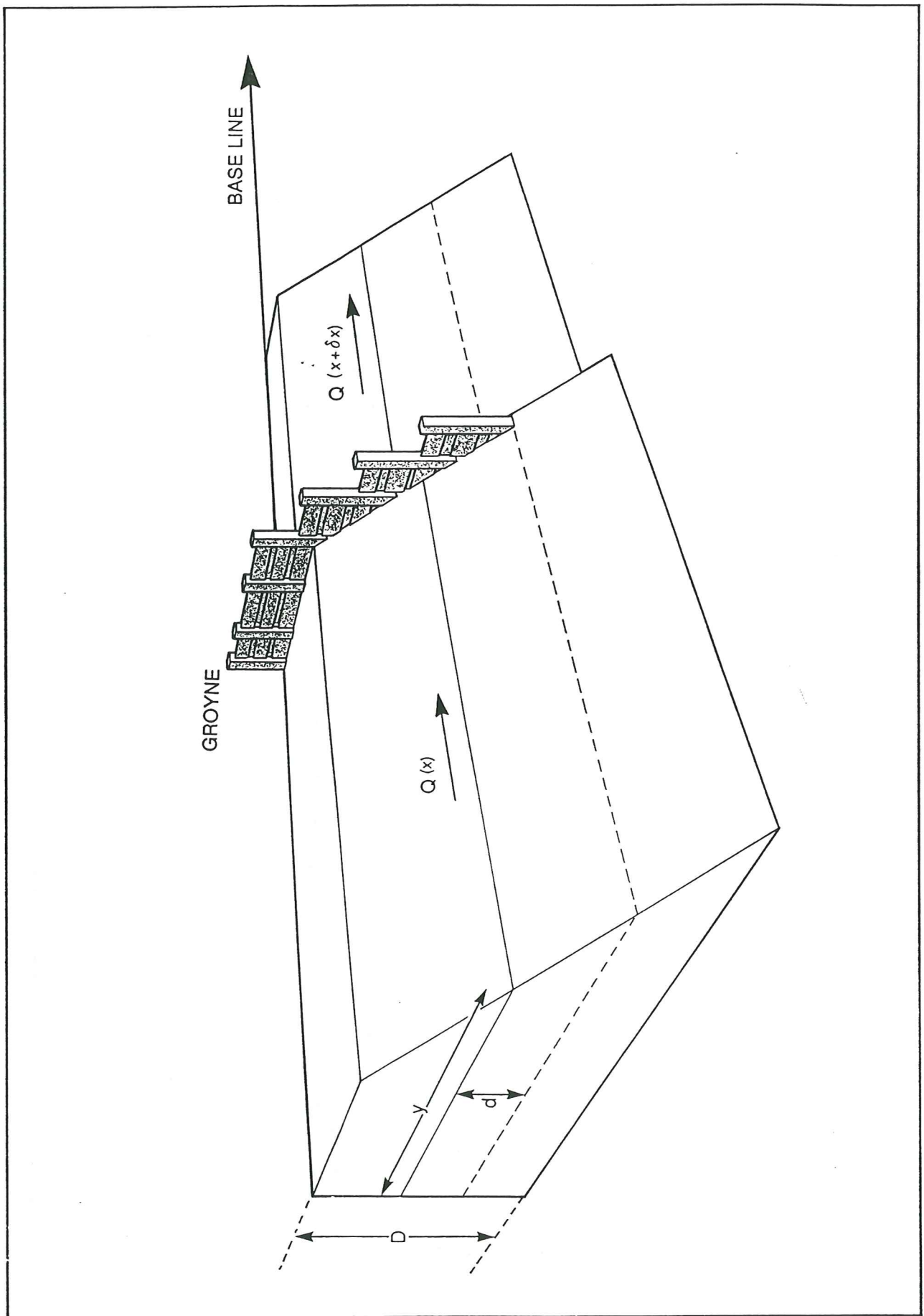

Fig 5 Simplified beach with groyne.

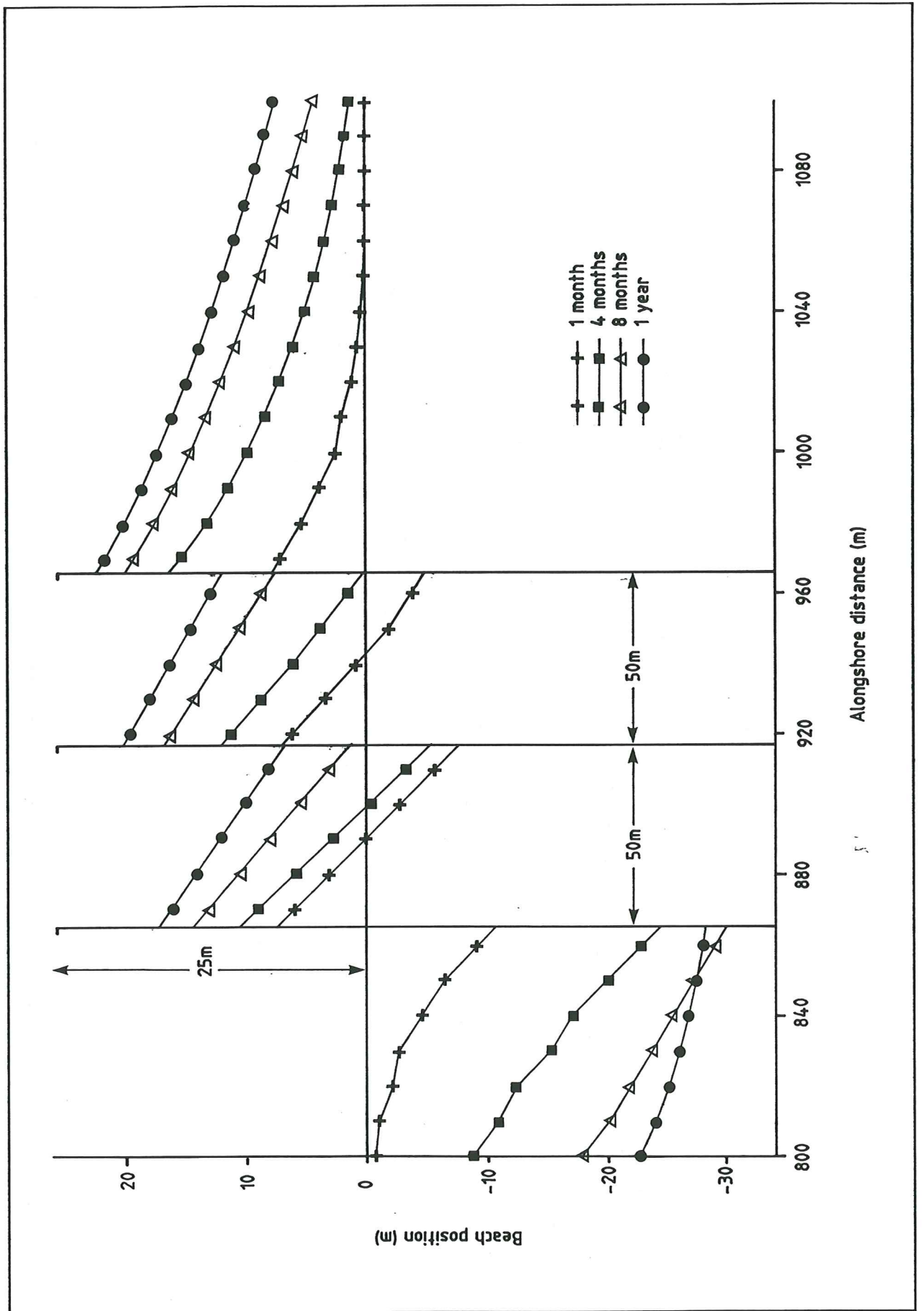

Fig 6a Beach development for 3 groyne system (0-1 year).

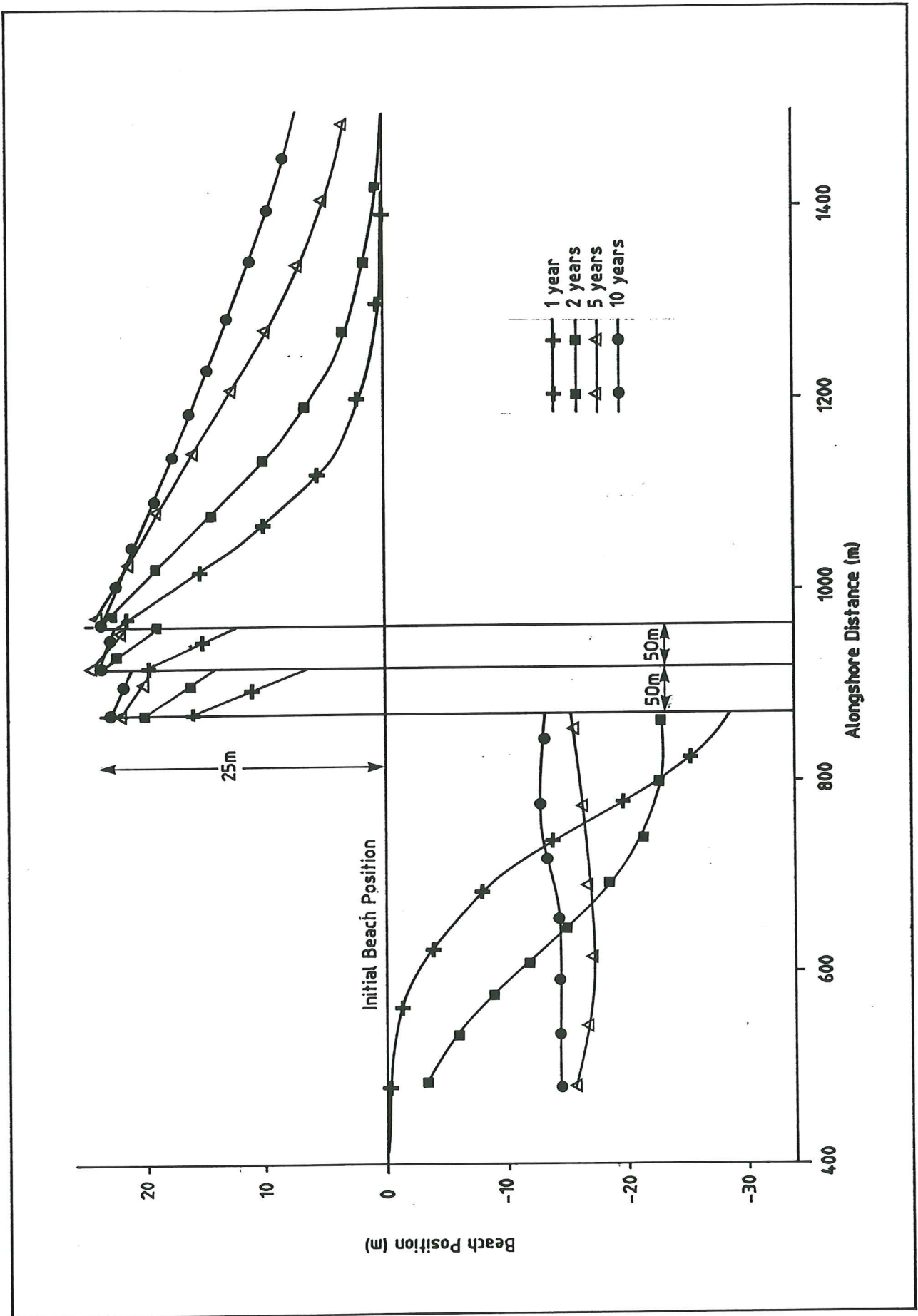

Fig 6b Beach development for 3 groyne system (1-10 years).

